

feather & black

Noah MidSleeper Reversible

IMPORTANT READ CAREFULLY RETAIN FOR FUTURE REFERENCE

Thank you for buying the Noah MidSleeper

- Please take a few minutes to read through these instructions before attempting to build this product
- Because of the size of this product we recommend that it is built in the room intended for use and that it is assembled by two adults
- As this product contains small parts please keep small children clear from the assembly area
- Carefully layout all the parts on a clean, flat surface and compare with the parts checklist. Save all packaging until assembly is complete to avoid accidentally discarding fittings

PRODUCT SAFETY

- Recommended Mattress Size: 190cm x 90cm. The thickness should not exceed the line marked on the upper end
- Do not allow children to jump on the bunks. Using this furniture other than for its intended purpose could cause damage to the structure or serious injury to your child
- Be aware of the danger of young children (under 6) falling from the upper bunk
- We recommend that you periodically check and ensure that all components are in their proper position, free from damage, and that all fittings are fully tightened
- Before each usage or assembly, inspect bed for damaged hardware, loose joints, missing parts or sharp edges. Do not use bunk bed if any parts are missing or broken
- Always use the ladder for entering and leaving the upper bunk
- Never attach or hang items to any part of the bunk bed that are not designed for use with the bed
- Noah MidSleeper has passed BS EN 747-1&2:2012
- Children can strangle in items such as ropes stings cords harnesses and belts attached to bunk bed/high bed

Warning: Children can become trapped between the bed and the wall. To avoid risk of serious injury the distance between the top safety barrier and the wall shall not exceed 75mm or shall be more than 230mm.

Warning: "High beds and the upper bed of bunk beds are not suitable for children under six years due to the risk of injury from falls"

PRODUCT CARE

- Wipe clean using a soft damp cloth followed by dry cloth
- Do not use abrasives or cleaning products which may contain ammonia or solvents
- Take Care when handling or moving the furniture. Careless handling can damage furniture, try to lift rather than drag
- TWO options of the Noah Midsleeper can be assembled(as below drawings)

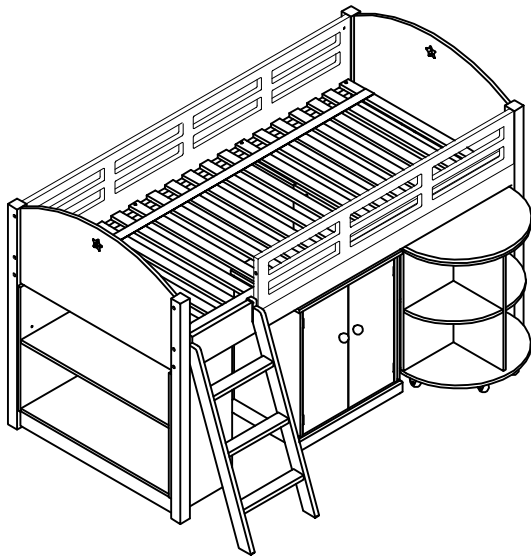

option 1

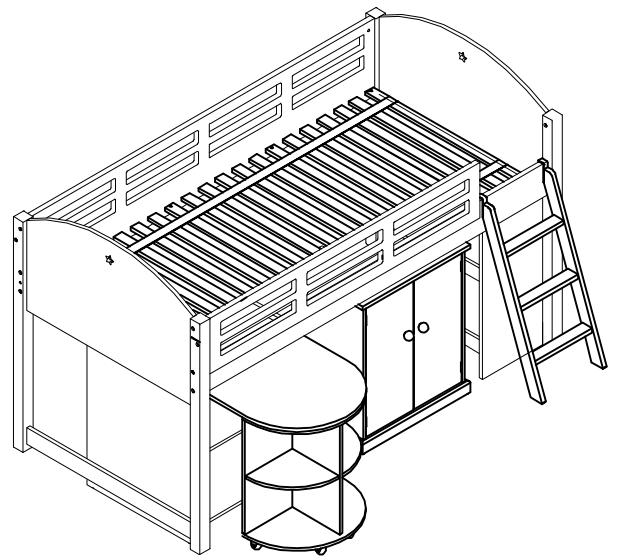







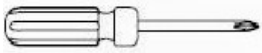

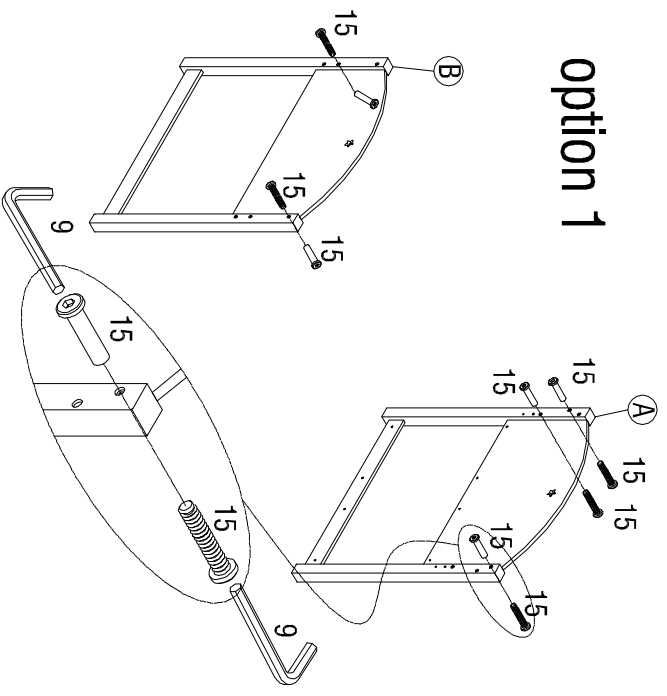







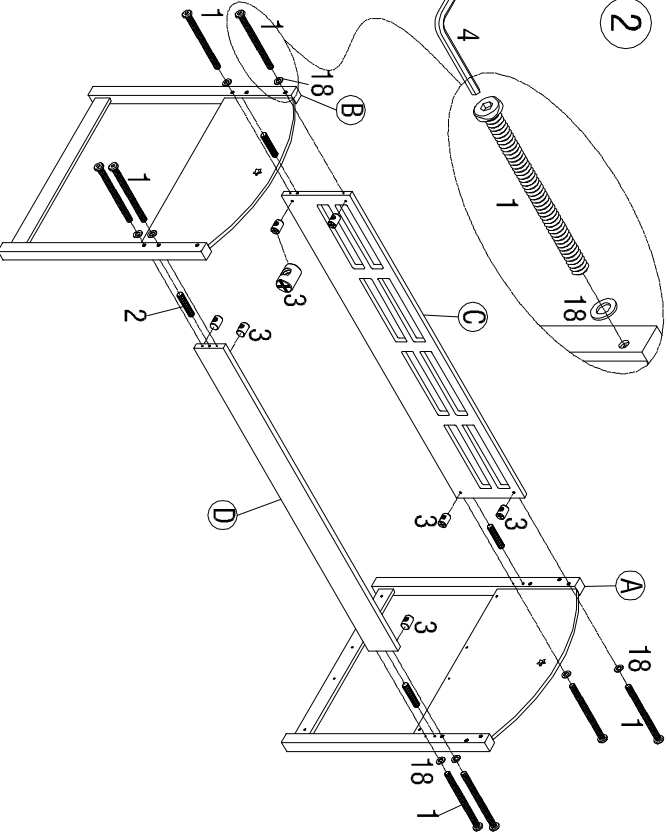

option 2

TOOLS REQUIRED

- Please use Philips Head Screwdriver (not included) and Allen key part 4, 9 (included) to assemble the Noah Midsleeper

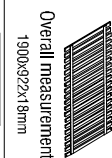
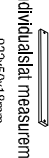

PARTS	QTY	
	1PC	<p>1</p> <p>option 1</p> 
	1PC	
	1PC	
	1PC	
	1PC	
	1PC	
	1PC	
	1PC	
	1PC	
	1PC	
	1PC	<p>2</p> 
	1PC	
	1PC	
	1PC	
	1PC	
	2PCS	
	1PC	
	1PC	
	1PC	
		

3

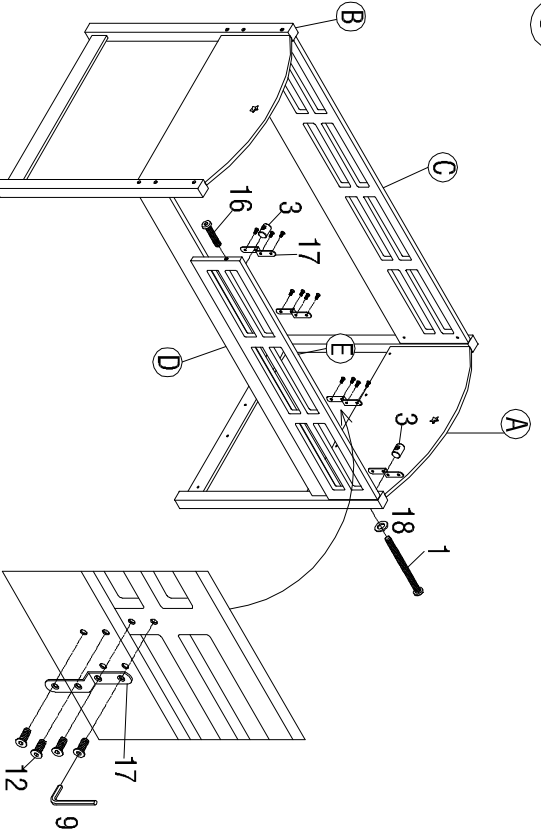

4

Shelf Unit Assembly

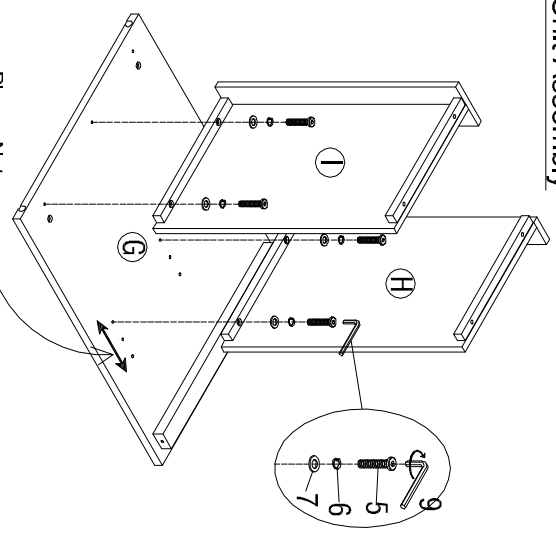

Please Note
The shelf (H) has 3 adjustable positions
in the end panels (F) and (G)

	HARDWARE	QTY
1	Allen head bolt Ø6x100mm	9PCS
2	Dowel Ø10x40mm	4PCS
3	5mm Allen key	10PCS
4	5mm Allen key	1PC
5	Allen head bolt Ø6x28mm	26PCS
6	Ø6mm	26PCS
7	Ø13mm	26PCS
8	Dowel Ø6x20mm	2PCS
9	Arm Allen key	2PCS
10	4PCS	4PCS
11	Wood screw Ø4x12mm	16PCS
12	Allen head bolt Ø6x12mm	22PCS
13	2PCS	2PCS
14	Wood screw Ø4x25mm	8PCS
15	5SET	5SET
16	Allen Head Bolt Ø6x15 mm	1PC
17	4PCS	4PCS
18	Ø16mm	9PCS

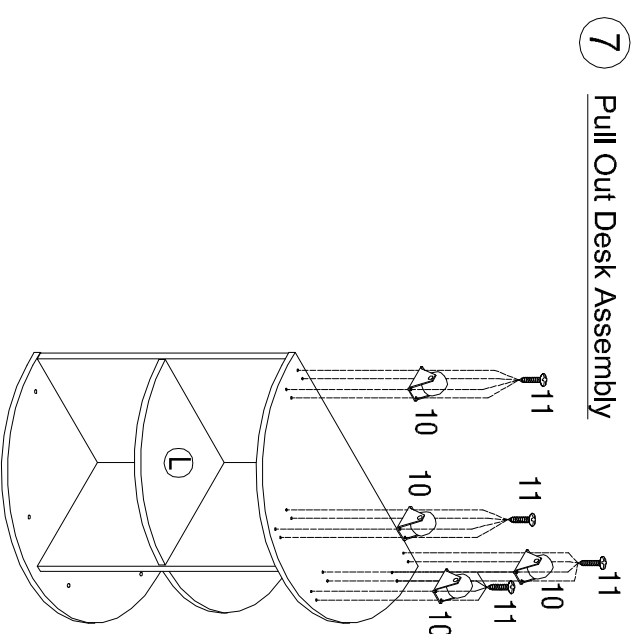
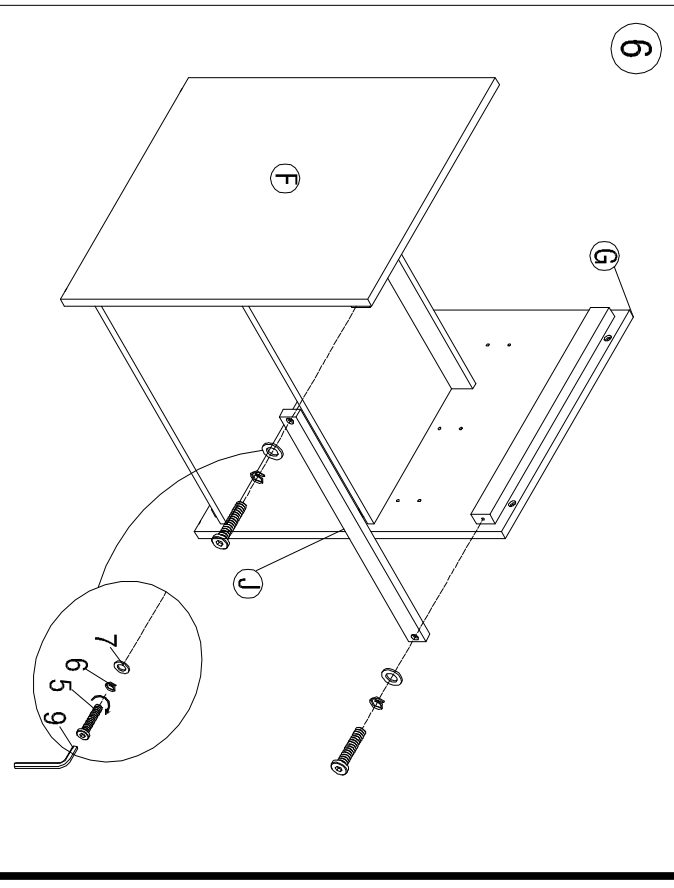
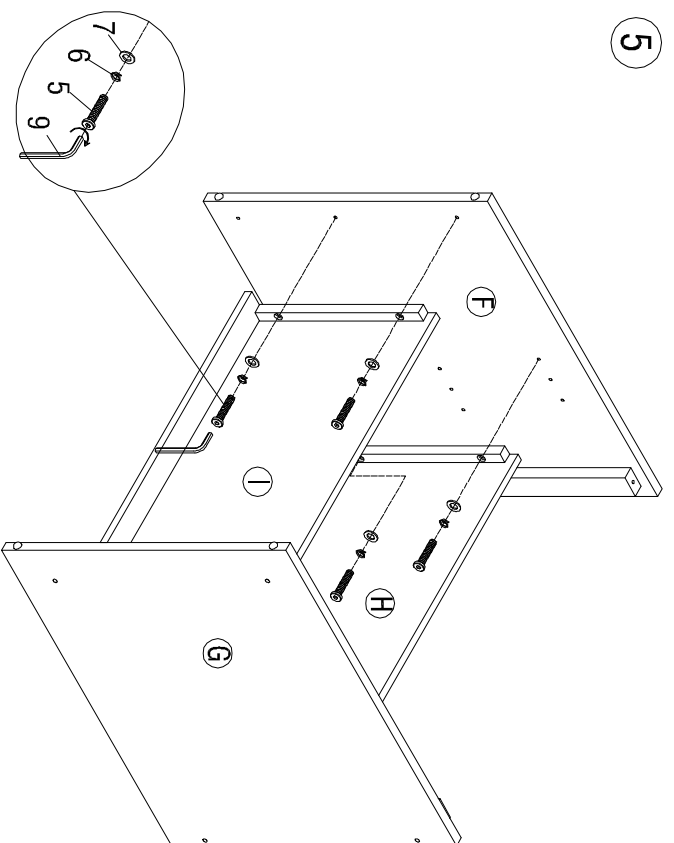

Fit castors to the base

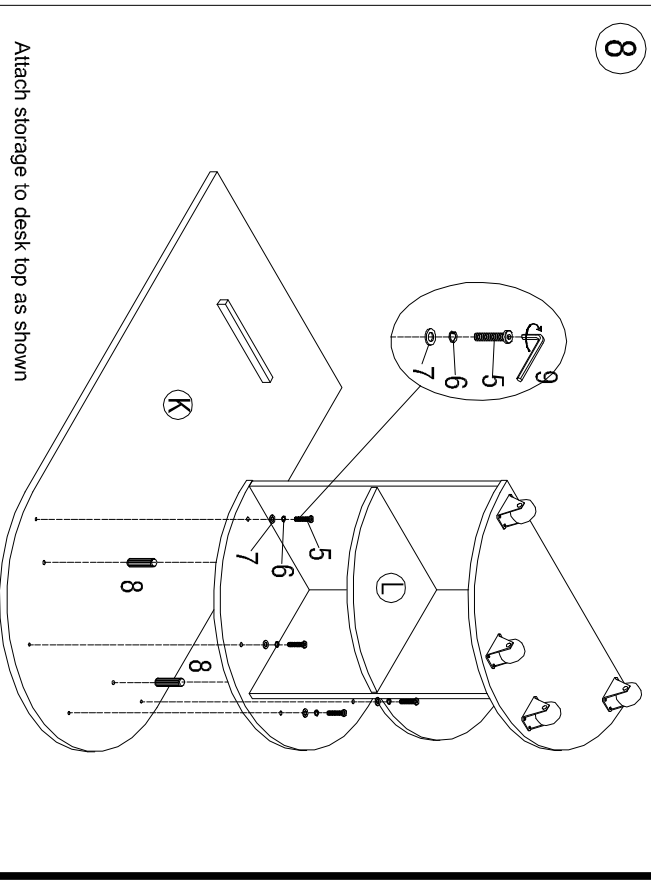

9

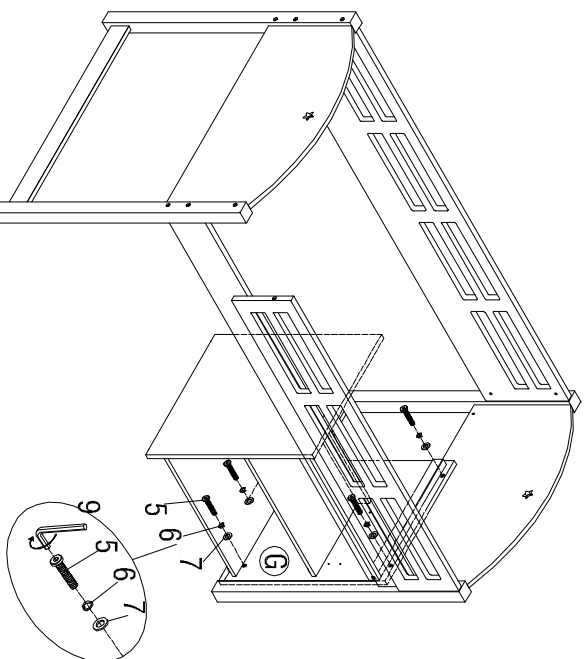

Secure the shelf unit to the bed frame as shown

10

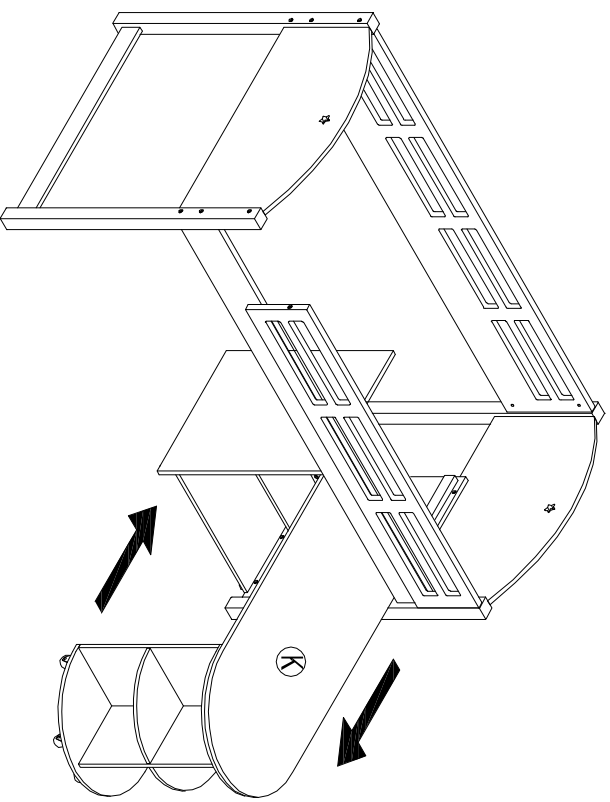

12

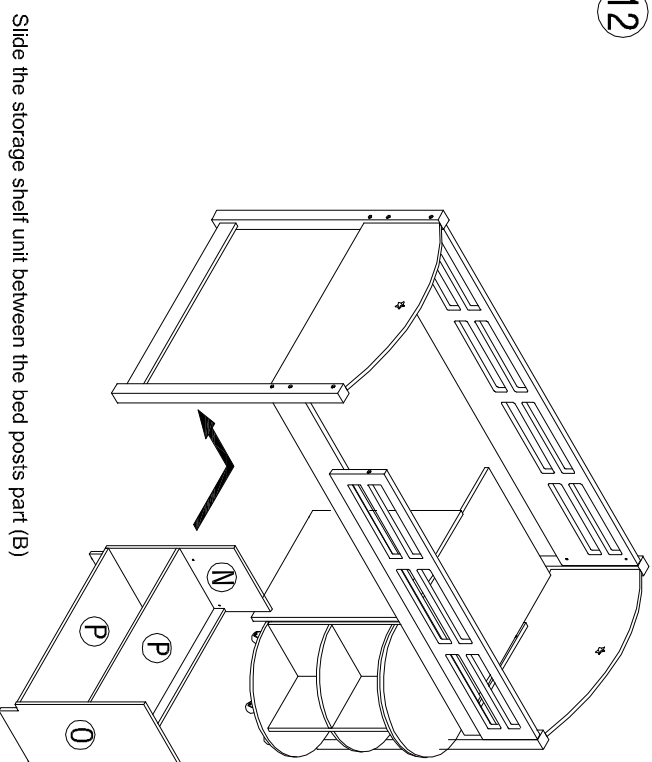

Slide the storage shelf unit between the bed posts part (B)

11

Storage Shelf Assembly

Please Note
The upper shelf (P) has 2 adjustable fitting positions in panels (N) and (O)

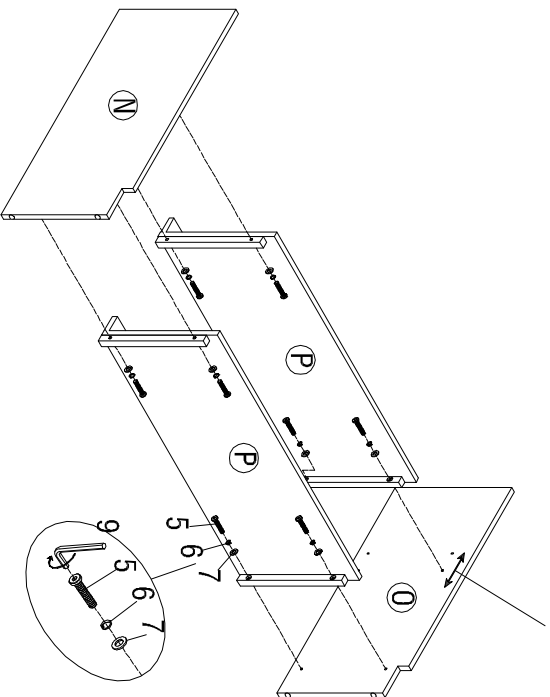

13

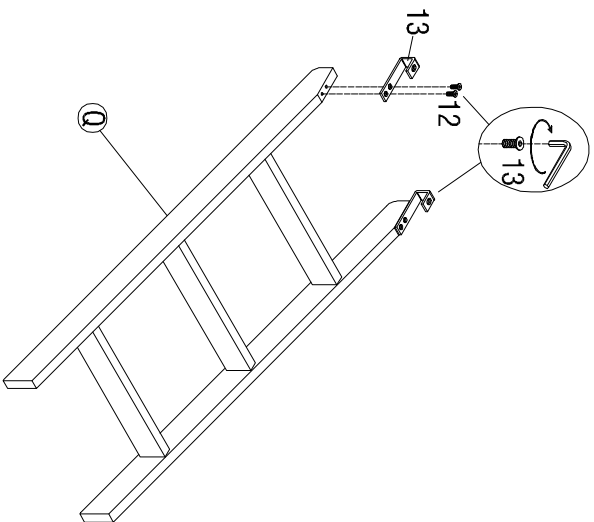

Fit the securing brackets (13) to ladder frame part (Q)

14

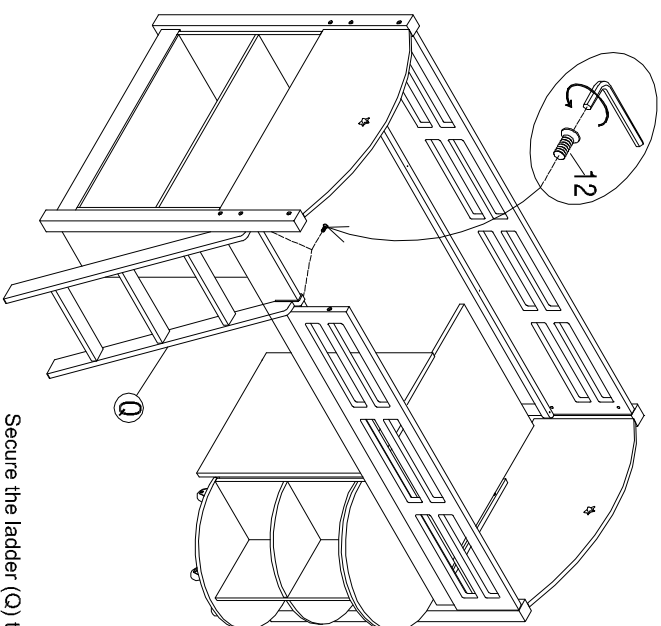

Secure the ladder (Q) to the bed frame (D)

15



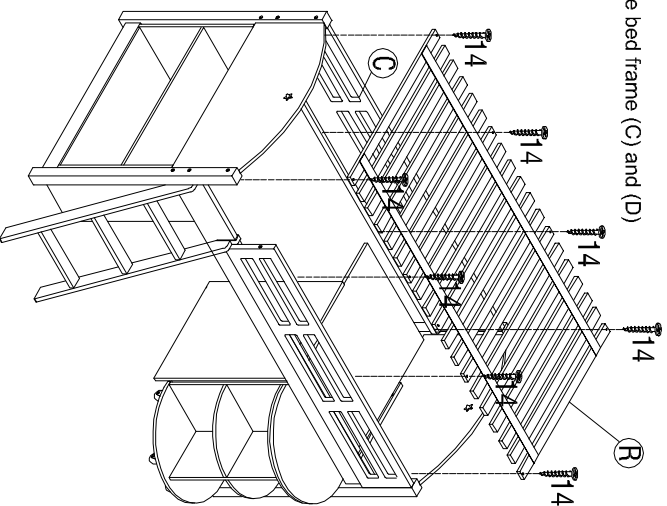



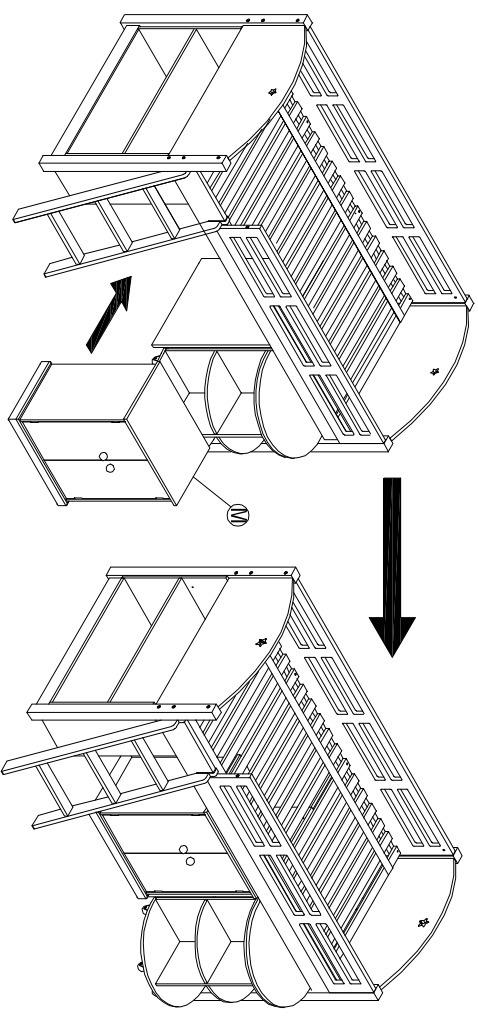



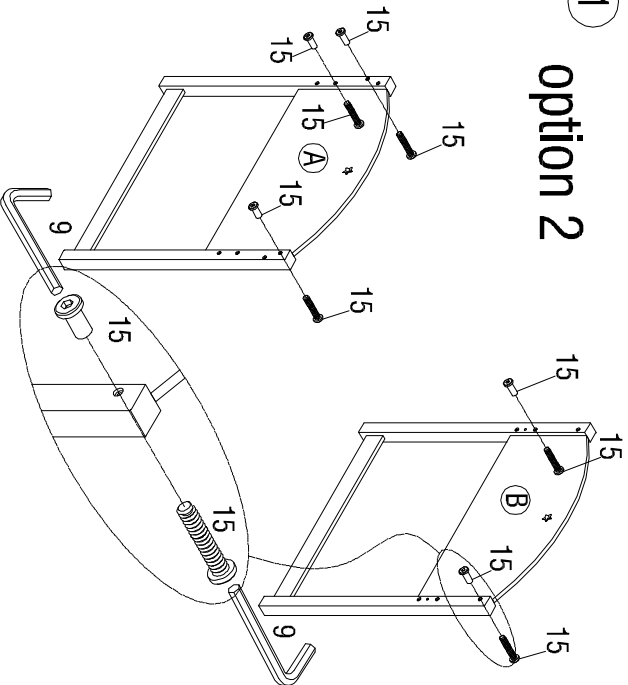
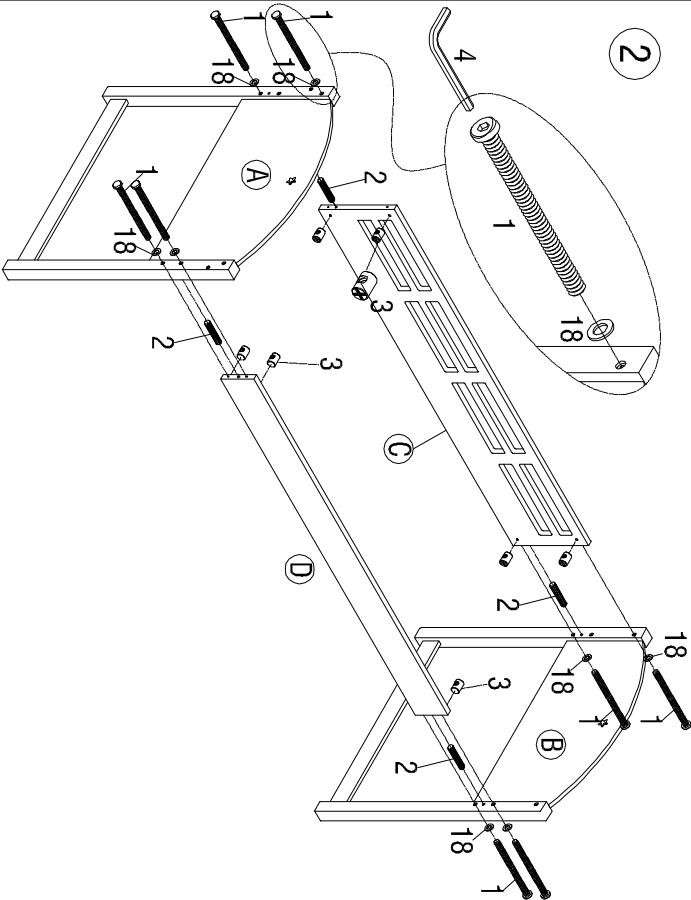









Secure the slats (R) to the bed frame (C) and (D)

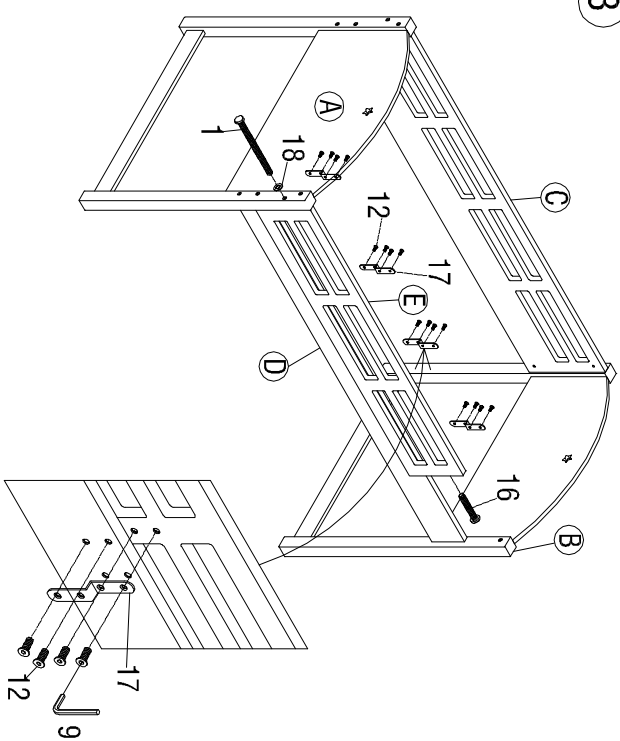

16

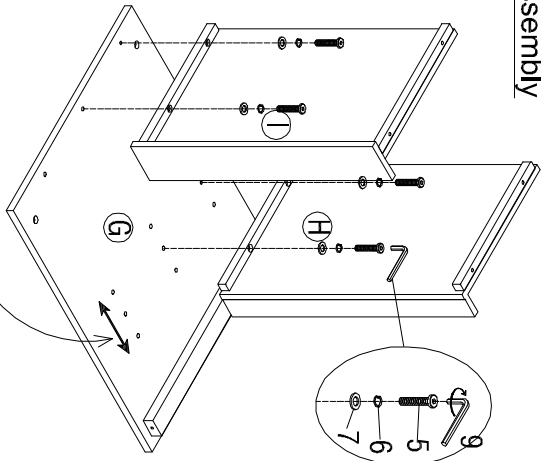

Slide the pre-assembled 2 door cabinet (M) under the bed frame as shown above

PARTS	QTY		
	1PC	<div style="display: flex; justify-content: space-between;"> <div style="width: 45%;"> <p>1</p> <p>option 2</p>  </div> <div style="width: 45%;"> <p>2</p>  </div> </div>	
	1PC		
	1PC		
	1PC		
	1PC		
	1PC		
	1PC		
	1PC		
	1PC		
	1PC		
	1PC		
	1PC		<p>3</p> 
	1PC		
	1PC		
	1PC		
	2PCS		
	1PC		
	1PC		
<p>Overall measurement 1900x922x18mm</p>  <p>Individual/slat measurement 922x50x18mm</p>		<p>4</p> <p>Shelf Unit Assembly</p>  <p>Please Note The shelf (H) has 3 adjustable positions in the end panels (F) and (G)</p>	

	HARDWARE	QTY
1	Allen head bolt Ø6*100mm	9PCS
2	Dowel Ø1*10mm	4PCS
3		10PCS
4	5mm Allen key	1PC
5	Allen head bolt Ø6*28mm	26PCS
6	Ø6mm	26PCS
7	Ø13mm	26PCS
8	Dowel Ø6*20mm	2PCS
9	Arm Allen key	2PCS
10		4PCS
11	Wood screw Ø4x12mm	16PCS
12	Allen head bolt Ø6x12mm	22PCS
13		2PCS
14	Wood screw Ø4x25mm	8PCS
15		5SET
16	Allen Head Bolt Ø6x15 mm	1PC
17		4PCS
18	Ø16mm	9PCS

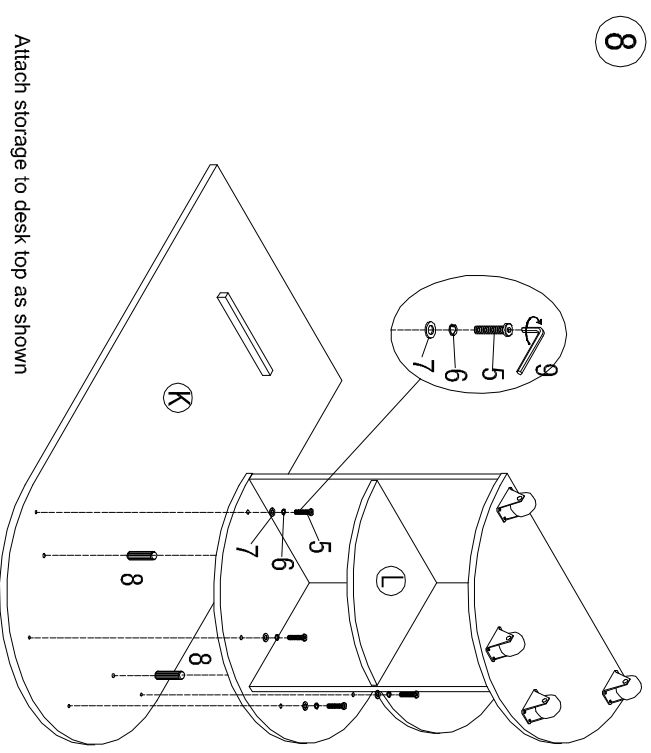
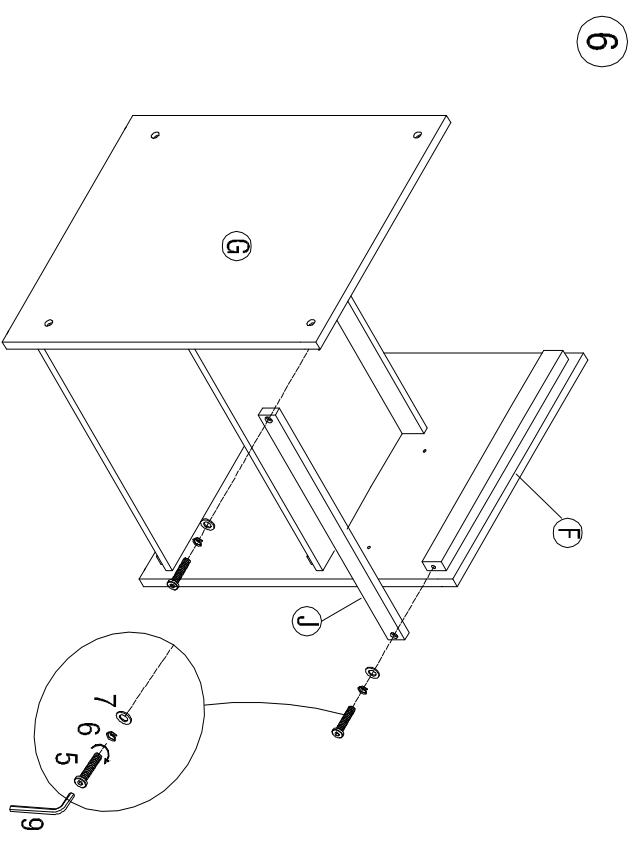
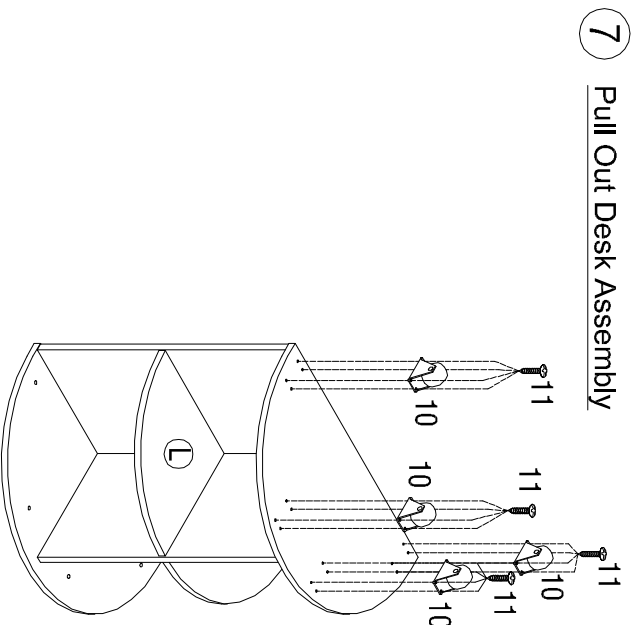
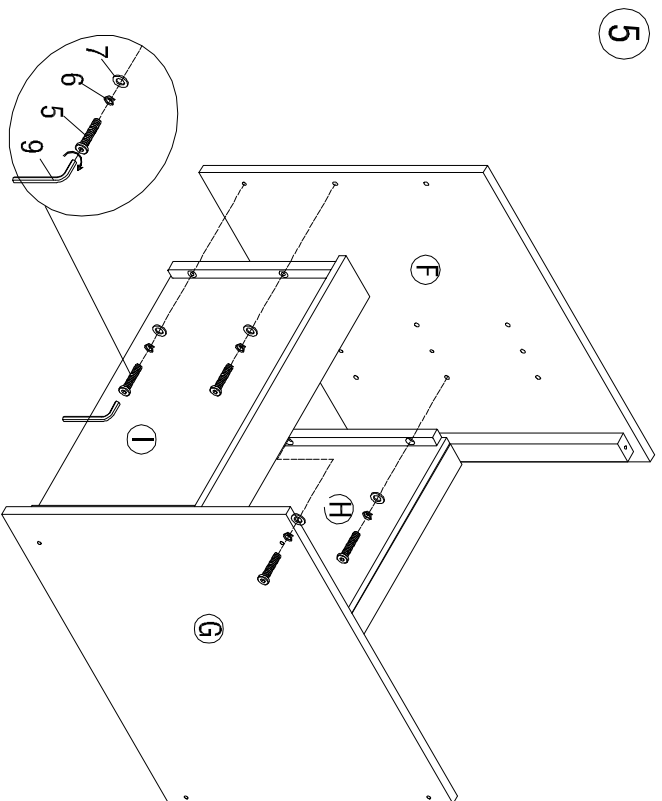

Fit castors to the base

Attach storage to desk top as shown

9

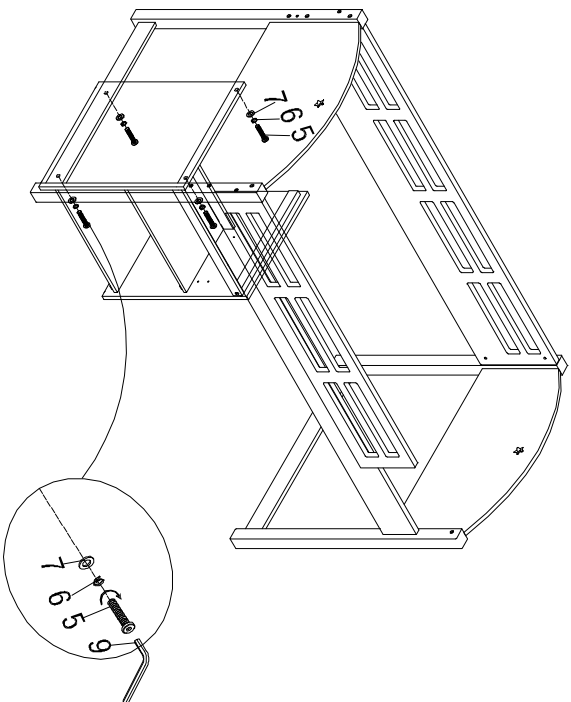

10

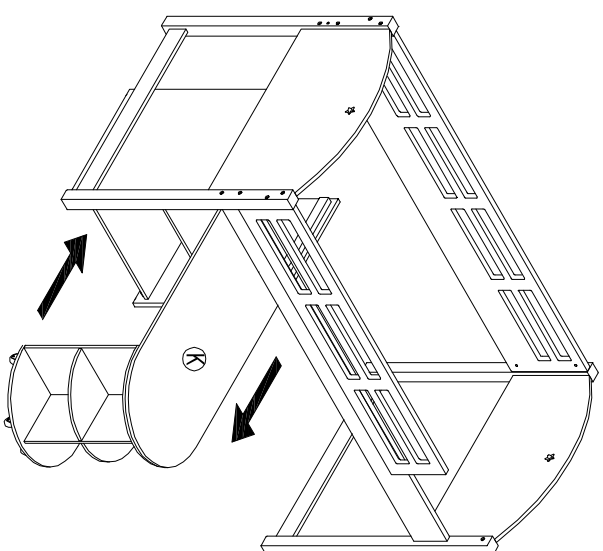

11

Storage Shelf Assembly

Please Note
The upper shelf (P) has 2 adjustable
fitting positions in panels (N) and (O)

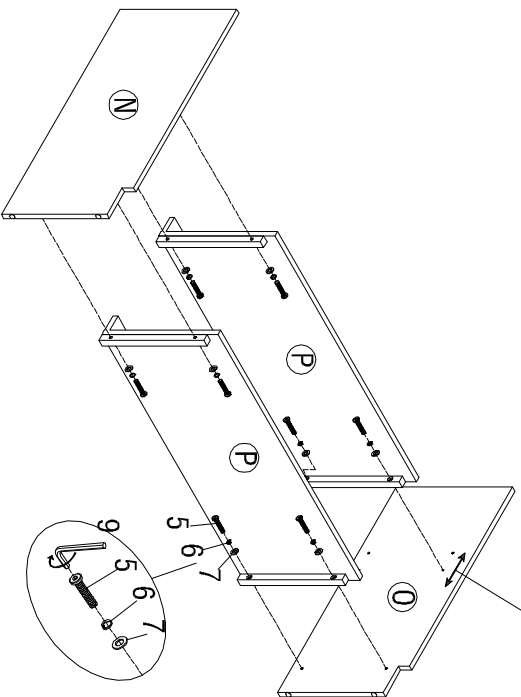

12

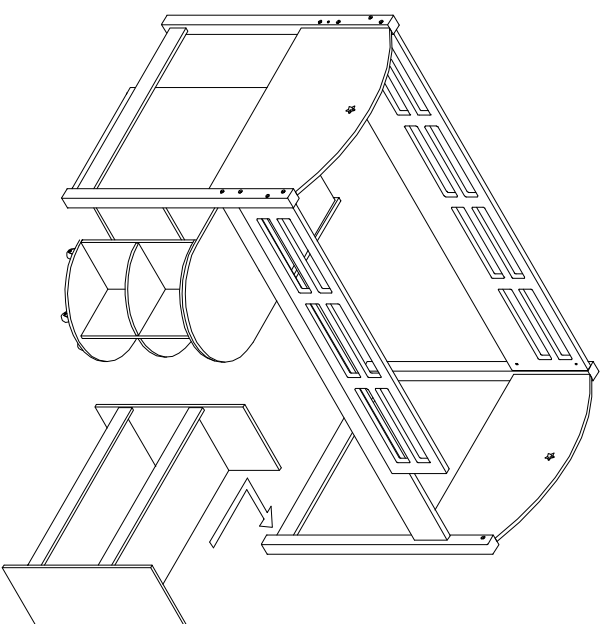

13

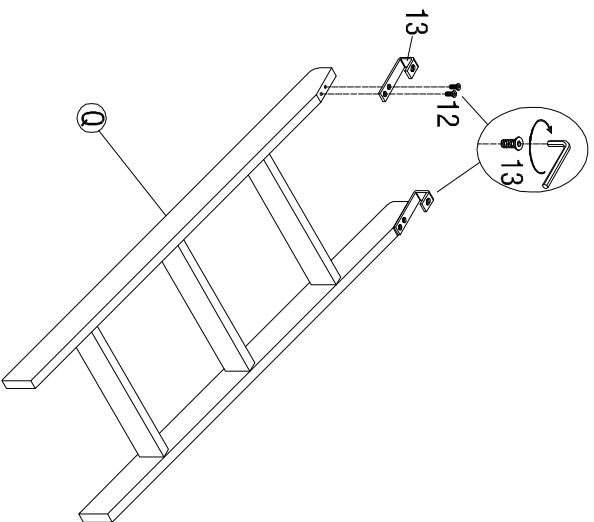

Fit the securing brackets (13) to ladder frame part (Q)

14

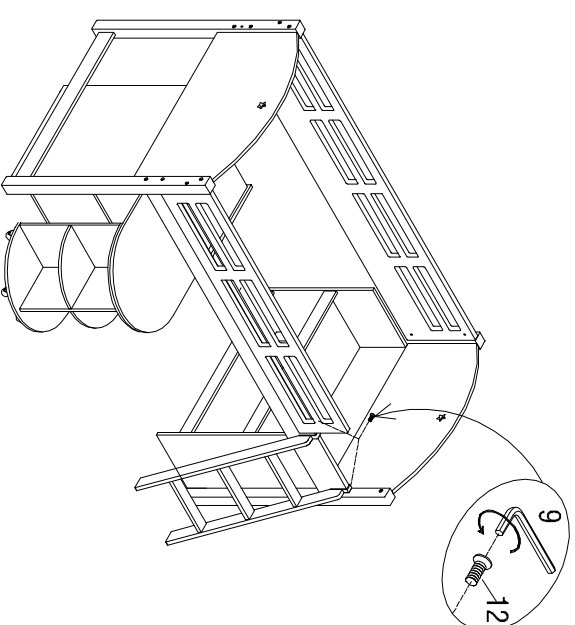

Secure the ladder (Q) to the bed frame (D)

15

Secure the slats (R) to the bed frame (C) and (D)

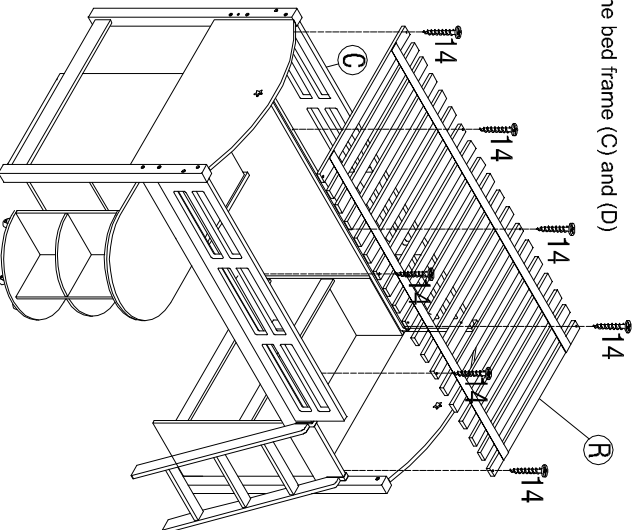

16

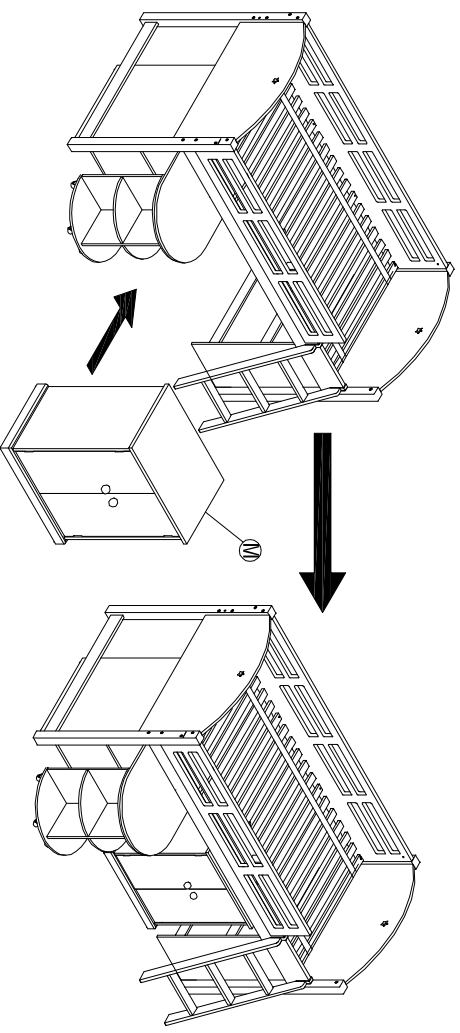

Slide the pre-assembled 2 door cabinet (M) under the bed frame as shown above