

# feather & black

## Salcombe Wardrobe - Assembly Instruction

Product size

W122 x D62 x H200 cm



If you require any advice during assembly, please call our customer service team on  
01243 380600

Please retain these assembly instruction for future use

# feather & black

## Salcombe Wardrobe - Assembly Instruction

### Before you start

Thank you for purchasing this Salcombe Wardrobe.

Please read these instructions fully prior to assembly to familiarise yourself with the various stages of construction. Carefully open all packs supplied and check the contents against the parts and fittings check list.

Do not destroy any of the packaging until you are certain that you have all the necessary parts for the assembly.

This item is heavy once assembled. Please try to assemble the item as close as possible to the point of use. Take care when moving the item to avoid personal injury or damage to the product and always lift rather than drag.

There are small components used in the construction of this furniture as well as plastic packaging, these should be kept away from young children whilst assembling.

#### Product Safety

All assembly fastenings should always be tightened properly, and care should be taken to ensure that no fittings are loose.

Periodically check and ensure that all components are in their proper position, free from damage, and that all connectors are tight.

Please note depending on the lighting, positioning and surroundings of your room, the shade of the colour can sometimes appear slightly different. Over a period of time the colour might lighten or fade slightly due to light exposure.

#### Product Care

To clean, slightly moisten cloth with water and wipe surfaces. A damp cloth holds dust and prevents damage. repeat with a dry, soft, lint-free cloth. Do not use abrasives or cleaning products which may contain ammonia or solvents.

Number of people required to assemble  
One people to assemble the product and two people to lift in to position.

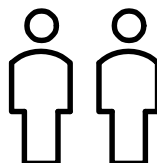

#### Time to assemble



**1 Hour**

#### Necessary tools

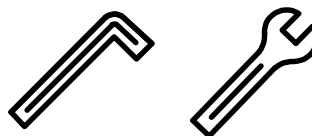

#### Missing parts or faulty products

If you are missing any fixtures or fitting during assembly, or a part is unfortunately faulty please call our customer service team on 01243380600

# feather & black

## Salcombe Wardrobe - Assembly Instruction

### Components supplied (not actual size)

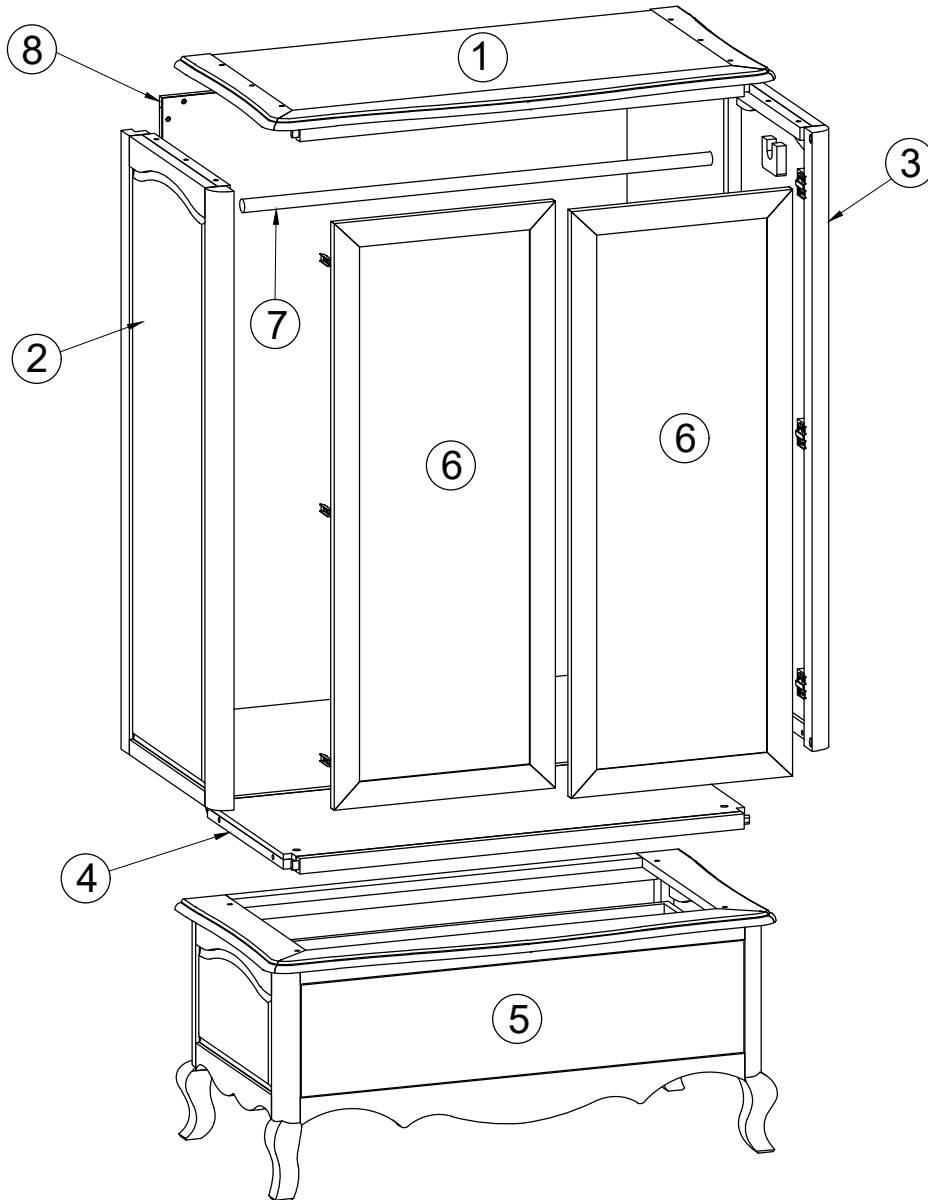

|                      |          |                  |           |
|----------------------|----------|------------------|-----------|
| (1) Top panel        | Qty: 1pc | (5) Base         | Qty: 1pc  |
| (2) Left side panel  | Qty: 1pc | (6) Doors        | Qty: 2pcs |
| (3) Right side panel | Qty: 1pc | (7) Hanging rail | Qty: 1pc  |
| (4) Center panel     | Qty: 1pc | (8) Back frame   | Qty: 1pc  |

# feather & black

## Salcombe Wardrobe - Assembly Instruction

### Fixtures and fittings supplied (not actual size)

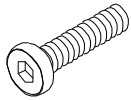

(9): Allen Bolt  
M6X30mm  
Qty: 14pcs

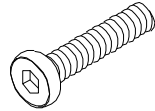

(10): Allen Bolt  
M8X40mm  
Qty: 10pcs

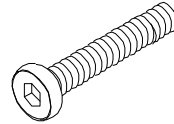

(11): Allen Bolt  
M8X50mm  
Qty: 4pcs

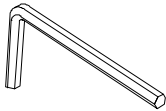

(12): Allen Key M4  
Qty: 2pcs

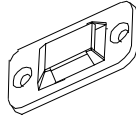

(13): Hanger Tip Kit  
Qty: 4pcs

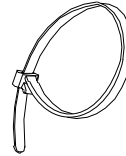

(14): Nylon strap  
Qty: 2pcs



(15): Screw  
M4X35mm  
Qty: 4pcs



(16): Screw  
M4X15mm  
Qty: 4pcs

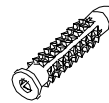

(17): Plastic Anchors  
Ø4x35mm  
Qty: 4pcs



(18): Bolt (for handle)  
M4X40mm  
Qty: 2pcs

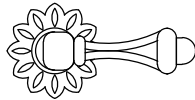

(19): Handle  
Qty: 2pcs

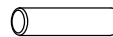

(20): Dowel wood  
Qty: 4pcs

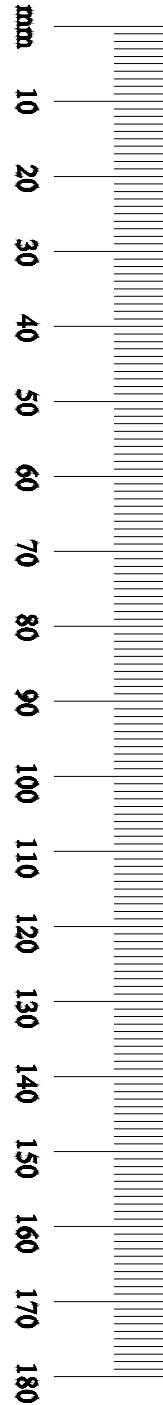

# feather & black

## Salcombe Wardrobe - Assembly Instruction

Step 1: Use bolt (10) to fix the Right side panel (3) and Left side panel (2) onto Center panel (4) and Top panel (1) by using Allen Key (12).

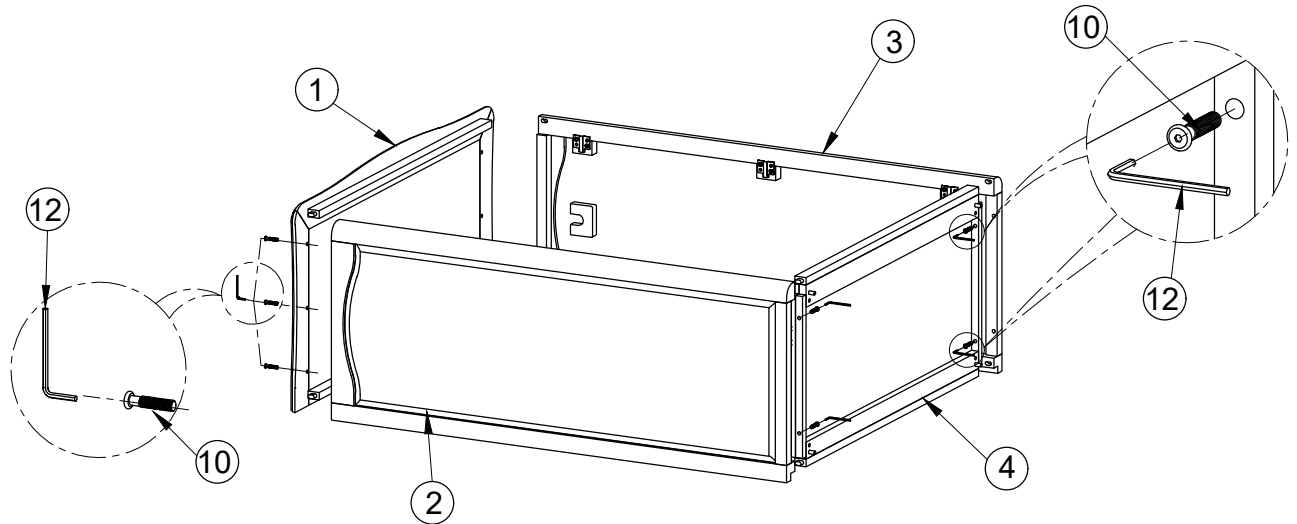

Step 2: Use bolt (9) to insert the Back panel (8) in Wardrobe by using Allen Key (12).

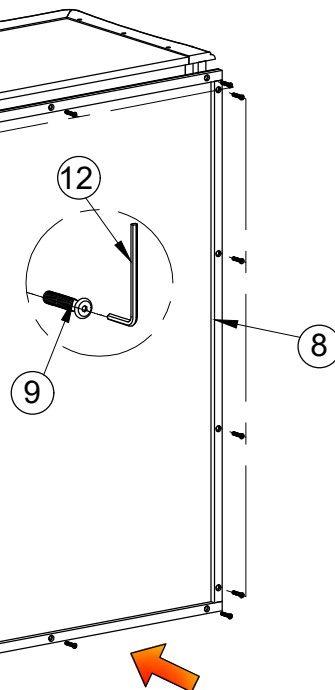

# feather & black

## Salcombe Wardrobe - Assembly Instruction

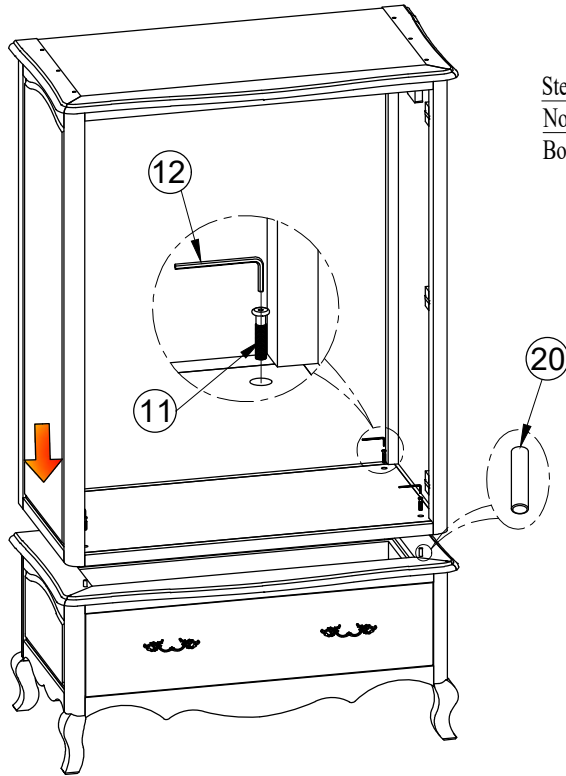

Step 3: Assembly the upper Box with Cabinet box

Note: Place the wooden dowel (20) in the correct position. Secure each frame with Bolt (11), fully tighten with the Allen key (12) provided.

Step 4: Insert hanging rail (7) into wardrobe

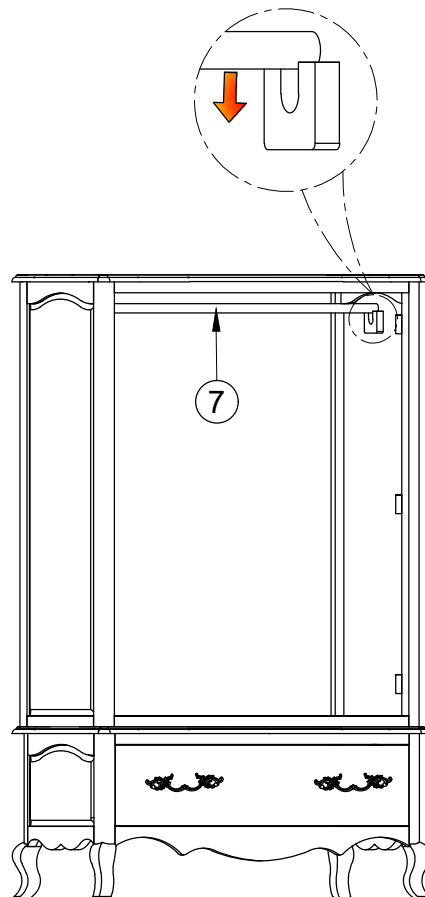

# feather & black

## Salcombe Wardrobe - Assembly Instruction

Step 5 : Fix doors (6) in by fixing the hinge positive and Sound enabled hinge.

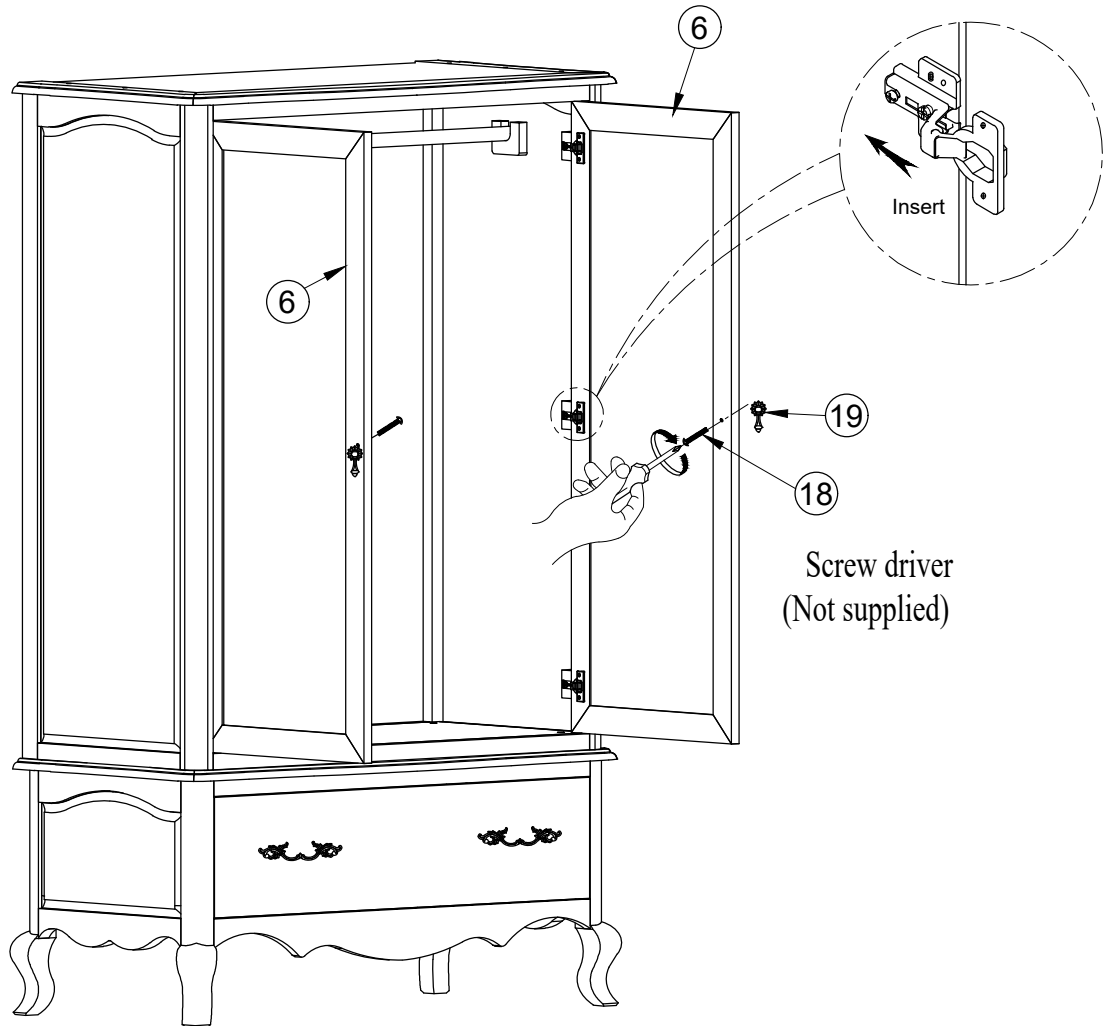
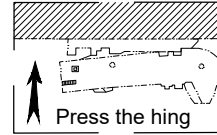

Step 6: Use Bolt (18) to fix the Handles (19) to the Doors.

# feather & black

## Salcombe Wardrobe - Assembly Instruction

Step 7 : If the doors are not closing all the way or are uneven with each other, use the adjustment points on each hinge to adjust accordingly, See illustration below.

Moves door forward or backward

Moves door left to right

Hinges can be adjusted for leveling the door as drawing shown.





# feather & black

## Salcombe Wardrobe - Assembly Instruction

Step 8:

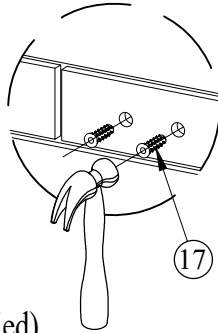
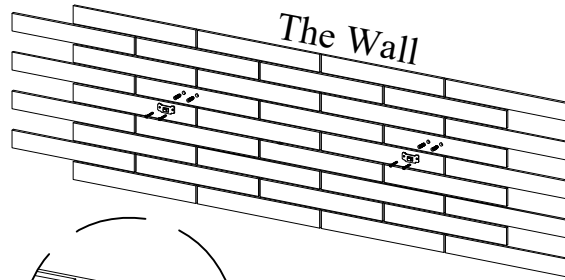

Hammer  
(Not supplied)

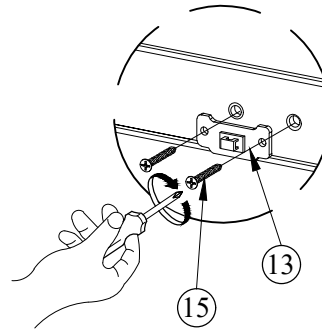

Screw driver  
(Not supplied)

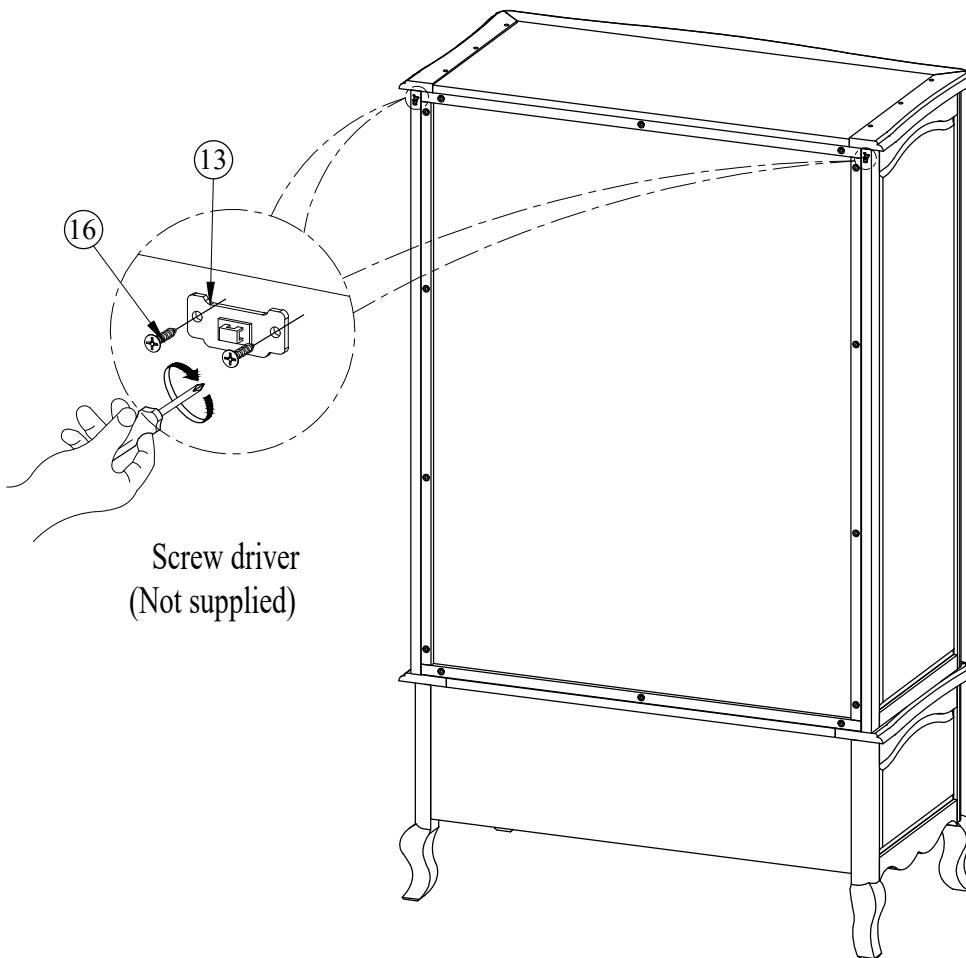

Screw driver  
(Not supplied)

# feather & black

## Salcombe Wardrobe - Assembly Instruction

Step 9:



# feather & black

## Salcombe Wardrobe - Assembly Instruction

